

SABER EXCAVATOR MOUNT

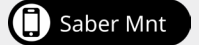

CREATIVE MOUNTING SOLUTION

The Saber Mount is designed to take the demanding torsional loads of helical pile installation. All Saber mounts provide full articulation allowing for accurate pile placement and installation. The integrated dual cradle feature provides user-friendly and productive Anchor Drive operation.



Connect the Saber Series Mount to any excavator quick coupler or linkage.

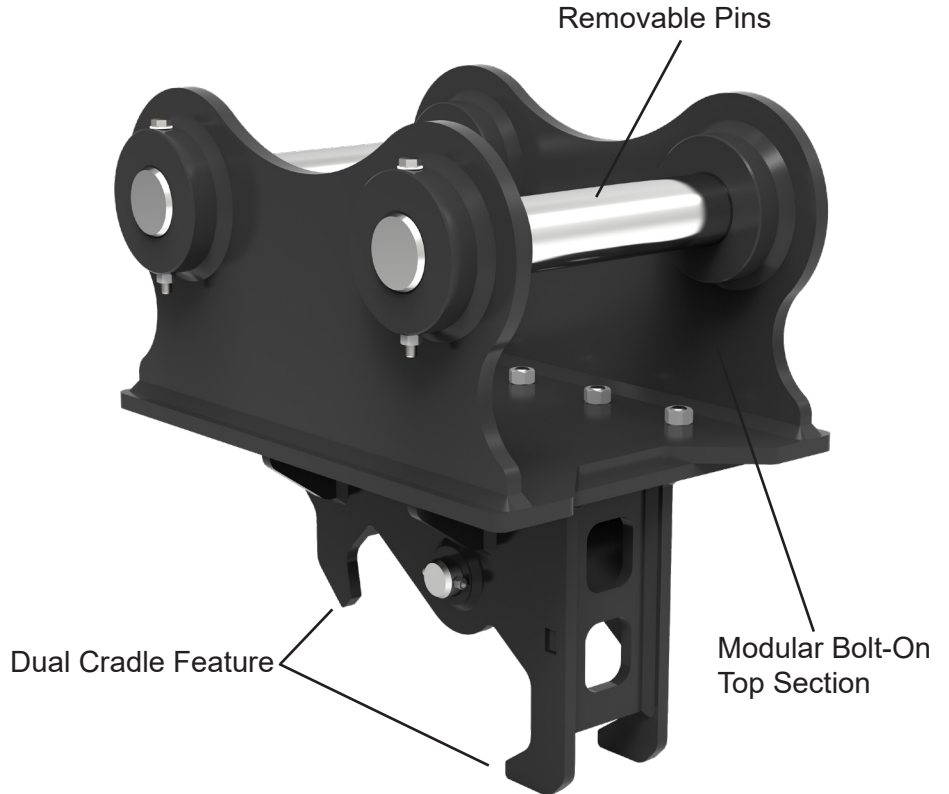

INNOVATIVE FEATURES

The removable top section allows the Saber Series to be used on a wide range of prime movers.

The pin-on link arm allows for full Anchor Drive articulation.

The dual cradle feature can position the Anchor Drive in ideal positions to improve pile connections and stops the Drive from swinging during transport.

The geometry of the dual cradle allows the Drive to be positioned parallel with the ground making pile connections safe and easy.

January 5, 2024 . Release 02



45MM SABER MOUNT



45mm Pin & Link Arm

Compatible Anchor Drive Models:

SA5, SA6, SA7, SA8, SA12, SA16, SA20, TA16, TA20

Torque Capacity: 20,000 ft-lbs (27,116 Nm)

75MM SABER MOUNT

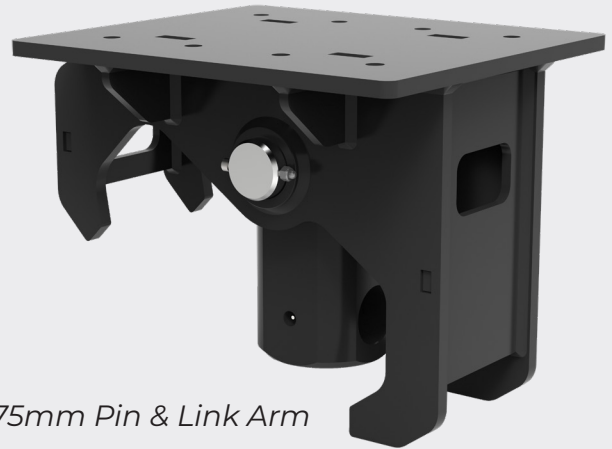

75mm Pin & Link Arm

Compatible Anchor Drive Models:

SA30, TA30, TA40, TA60, TA80

Torque Capacity: 80,000 ft-lbs (108,465 Nm)

ULTIMATE ADAPTABILITY - Designed to fit any type of backhoe or excavator.



PILE CONNECTIONS MADE EASY

The Saber Mount gives the operator complete control of the job site and the pile connection.

Position the Anchor Drive in any position to make quick work of pile connections.



The Anchor Drive can be positioned with the shaft pointed away or towards the operator using the front or rear cradle features.



Dinamic Oil North America is the US-based subsidiary of Dinamic Oil SpA., Headquartered in Modena, Italy.

Dinamic Oil North America

4725 Entrance Drive, Suite A
Charlotte, North Carolina, USA
704.587.4600 | dinamicoil.us

© 2024 Dinamic Oil North America All Rights Reserved

