

EXCAVATOR MOUNTING INFORMATION FORM



Use this form to provide the required mounting dimensions of the excavator. Although we have OEM specifications on file, we ask you to verify dimensions to ensure correct fitment of your order.

Important dimensions required: Pin Diameters, Ear Spread, Pin Center to Center.

Using a tape measure or caliper take measurements A, B, C, D as accurately as possible and complete this form. - *Note this form can be completed electronically (fillable PDF) and submitted via email.*

Note: Pin diameter measurements are typically in 5mm increments, so it is common for pins to be 90mm, 100mm etc.

Date

Customer Name

Excavator Model

Quick Coupler Model

Dimension A (Bushing to Bushing Width)

Dimension B (Center to Center)

Dimension C (Front Diameter)

Dimension D (Back Diameter)

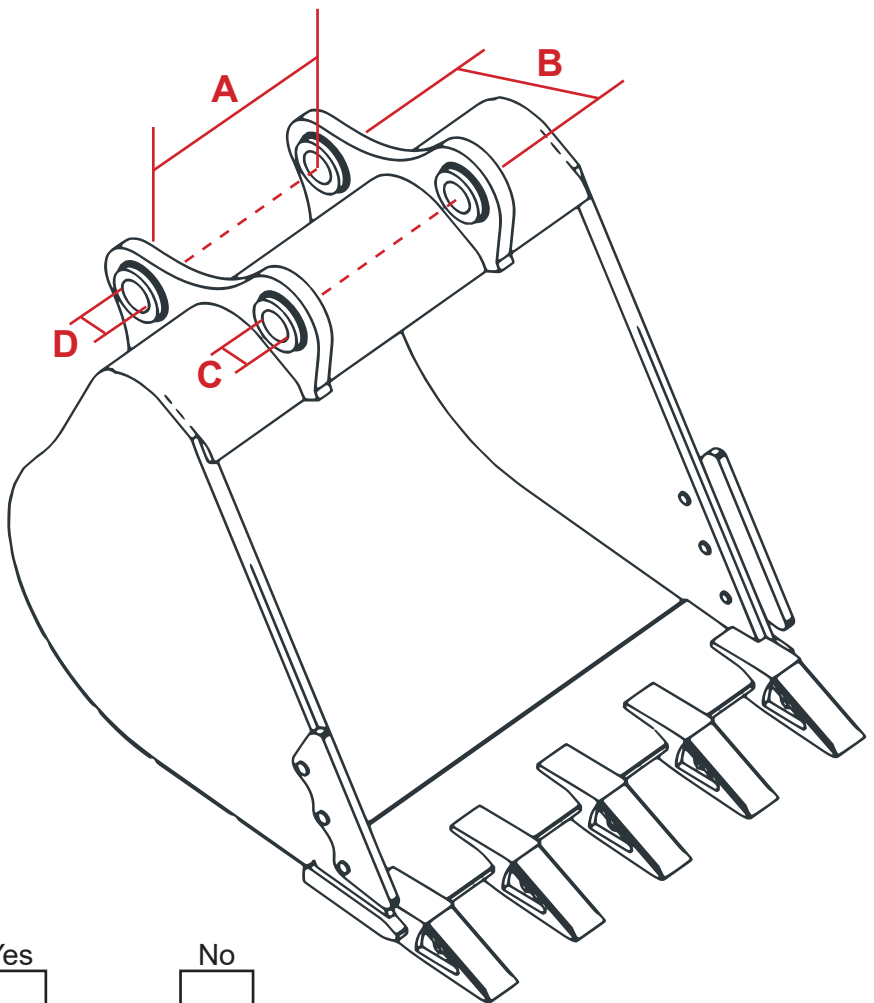

Yes No
Do You Require Pins?

Additional Notes